

D2848

V8 diesel engine for power generation



Unlimited Power Generation

MAN diesel power units are built to satisfy the exact demands of power generation. Rated in the emergency mode for maximum electrical power output (LTP), the power units feature dependable and rapid load acceptance. In the prime power mode (PRP) the units exhibit exceptional endurance with an average operational performance of about 4 000 h/a. Backed by absolute reliability, consistent power availability and exemplary economy, MAN diesel power units qualify for almost unlimited power generation.

Engine Description D2848

Characteristics

Cylinder and arrangement	8-cylinder V-design
Operation mode	4-stroke diesel engine with direct injection
Charging	Exhaust turbocharger with intercooler
Type of cooling	Water circulation by centrifugal pump on engine
Injection	Bosch in-line pump with integrated, electromagnetic actuator
Engine control	GAC-electronic control unit available in different variations

Dimensions D2848

A-Overall length with fan-cooled radiator	mm	1 850
B-Overall width with fan-cooled radiator	mm	1 400
C-Overall height with fan-cooled radiator	mm	1 700
D-Height from bottom of engine to crankshaft centre	mm	467
Weight (dry)	kg	1 250

Customer Benefits

- High power ratings with environmentally-friendly operation
- High efficiency due to low fuel and lube oil consumption as well as low maintenance
- Fast response characteristic to load changes and safe handling of peak load
- Reliable operation and long lifetime
- Robust, compact design

Technical Data D2848

Operation		LTP		PRP	
at speed	rpm	1 500 (50 Hz)	1 800 (60 Hz)	1 500 (50 Hz)	1 800 (60 Hz)
Type of engine		LE 213	LE 213	LE 211	LE 211
Bore	mm	128	128	128	128
Stroke	mm	142	142	142	142
Displacement	l	14.6	14.6	14.6	14.6
ISO fuel stop power ¹	kW	495	539	-	-
Torque	Nm	3 151	2 801	-	-
ISO standard rating ²	kW	-	-	405	460
Torque	Nm	-	-	2 623	2 440
Genset rating net	kVA	550	600	450	500

¹ Continuous power for limited period without overload capability. ² Variable continuous power with 10% overload capability.

Definition of Application

Engines for LTP (Limited Time Running Power) are designed for up to 300 annual operation hours at a load factor up to 100%. Normally the engines are used for emergency generating sets.

Engines for PRP (Prime Power) are designed for 4 000 annual operation hours at a load factor of 70%. These engines are used for peak-load operation.

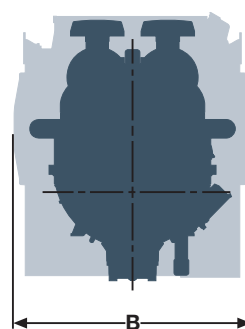
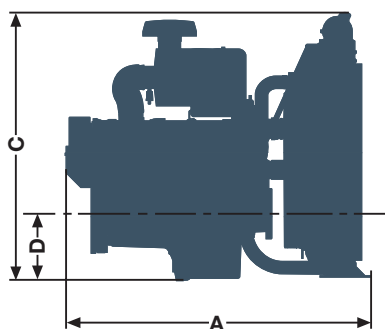

MAN Nutzfahrzeuge AG
Business Unit Engines
Department MVL
Postfach 44 02 58
90207 Nuremberg, Germany

engines.components@de.man-mn.com
www.man-engines.com

A member of the MAN Group



D 114.422/E · ms 10074 · Printed in Germany
Text and illustrations are not binding.
We reserve the right to make modifications in the course of technical progress.